



## BF Series

### Single Bag Housings: #1, #2, #3 and #4 sizes

Shelco® BF series bag housings are manufactured of 304L or 316L stainless steel and carbon steel. Designed for 150 PSI (10 bar) and for temperatures to 300°F. Protective poly coat over stainless steel is standard finish. Positive hold down spring and adjustable stainless leg assembly are standard features on the #1 and #2 size housings.



### Features #1 and #2 size

- Stainless Steel or Carbon Steel construction
- 150 PSI rated design
- Band clamp or swing bolt lid closures
- Stainless steel compression spring included
- Adjustable Stainless Steel leg assembly
- 2" FNPT, side inlet and bottom outlet
- All housings come standard with Buna O-rings
- ¼" NPT gauge ports clean and dirty side
- ¼" NPT vent in head with ½" NPT bottom drain
- 1/8" Perf stainless steel basket

### Features #3 and #4 size

- 316 Stainless Steel construction
- 150 PSI rated design
- Clamp closures
- ¾", 1" or 1 ½" FNPT inlet and outlet
- Side inlet and bottom outlet
- Standard with Buna O-rings
- ¼" NPT vent port in lid
- 1/8" Perf stainless steel basket

### Standard Design Specifications

Model	Closure	Bag Size	Flow Rate Gpm*	Std Pipe Size†	Drain	Vent	Shipping Weight	Box Size Clamp	Shipping Weight SB	Box Size Swing Bolt
BFS-3C	Clamp	#3	30	1.5" FNPT	—	1/4" NPT	10 lbs	7x7x18	—	—
BFS-4C	Clamp	#4	60	1.5" FNPT	—	1/4" NPT	14 lbs	7x7x28	—	—
BFS-1	Clamp or Swing Bolt	#1	100	2" FNPT	1/2" NPT	1/4" NPT	43 lbs	18x18x38	73 lbs	18x18x42
BFS-2	Clamp or Swing Bolt	#2	180	2" FNPT	1/2" NPT	1/4" NPT	53 lbs	18x18x45	83 lbs	18x18x50
BFC-1	Clamp or Swing Bolt	#1	100	2" FNPT	1/2" NPT	1/4" NPT	45 lbs	18x18x38	73 lbs	18x18x42
BFC-2	Clamp or Swing Bolt	#2	180	2" FNPT	1/2" NPT	1/4" NPT	55 lbs	18x18x45	83 lbs	18x18x50

\* Flow rates are for guide lines only, actual flow rates are based on fluid, viscosity, Bag type, micron ratings and other factors. It is recommended if your flow rate is greater than 150 gpm that you increase your pipe size to 3" to reduce the pressure drop across the housing.

† Maximum inlet and outlet port size is 3" for the #1 and #2 size housings.



## Dimensions

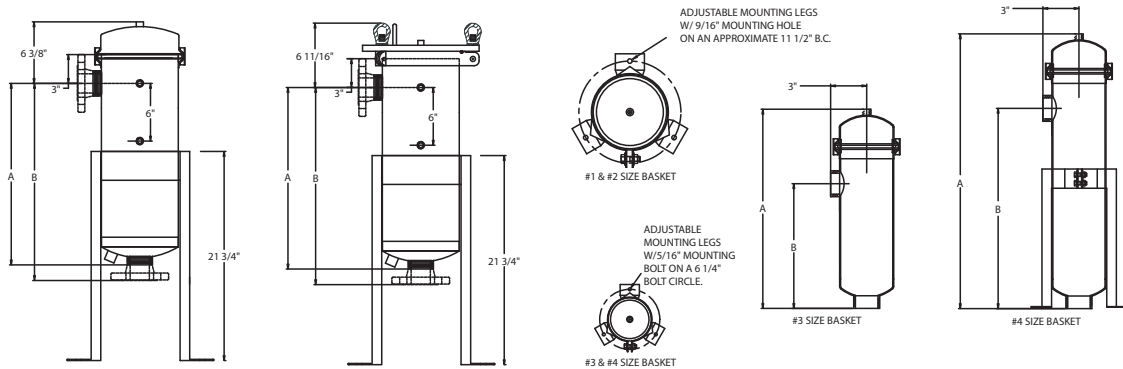

MODEL	DIM. A	DIM. B
#1 SIZE	18 7/8"	20 1/2"
#2 SIZE	34 7/8"	36 1/2"

MODEL	DIM. A	DIM. B
#3 SIZE	16 9/16"	10 3/8"
#4 SIZE	22 7/8"	16 11/16"

### ORDERING GUIDE #1 and #2 Sizes

BFS	2	C	2	316	2	E
Product Code	Size	Closure	Connection	Material Options	Style	Gaskets
BFS = Stainless Steel BFC = Carbon Steel	1 = 7x18 2 = 7x32	C = Clamp SB = Swing Bolt	2 = 2" FNPT 2F = 2" RFF 3 = 3" FNPT 3F = 3" RFF 2TC = 2" TC	Blank = 304 316 = 316 SS 134 = *3M 134 Coating over 304 SS	Blank = Side in, Bottom out 2 = Side in, Side out	Blank = Buna E = EPR S = Silicone V = Viton T = Teflon

\*Note: 134 coating must have swing bolt closure and flanged connections.

### ORDERING GUIDE #3 and #4 Sizes

BFS	4	C	1	2	E	
Product Code	Size	Closure	Connection	Material	Style	Gaskets
BFS = Stainless Steel	3 = 4x8 4 = 4x14	C = Clamp	75 = 3/4" FNPT 1 = 1" FNPT 1.5 = 1 1/2" FNPT	Blank = 316 SS	Blank = Side in, Bottom out 2 = Side in, Side out (Hold down spring recommended)	Blank = Buna E = EPR S = Silicone V = Viton T = Teflon

## Options

- Coatings: 3M 134 coating for sea water and corrosive applications
- 10 mesh wire baskets or special mesh lined baskets
- Special porting arrangements (side in/side out)
- Specialty baskets to hold bulk carbon or resin
- Wide variety of connections; flanged, BSP, and sanitary ferrules
- Electro-polishing available
- Adjustable stainless legs and compression spring are available for the #3 and #4 size housings.



Complete line of bag filter media



Stainless steel basket, spring and leg assembly



tel: 860.854.6121  
800.543.5843  
fax: 860.854.6120  
e-mail: info@shelco.com  
www.shelco.com

**SHELCO FILTERS**

100 Bradley Street . Middletown, CT 06457 . USA

Bulletin: BFH-400.4  
© 2006 Shelco Filters

MicroVantage™, MicroSentry™, ShelcoFilters®, and the Shelco Filters logo are registered trademarks of the Tinny Corporation  
Shelco Filters is a division of the Tinny Corporation.

